

# MDC150 - 050301 Brushless Speed Controllers

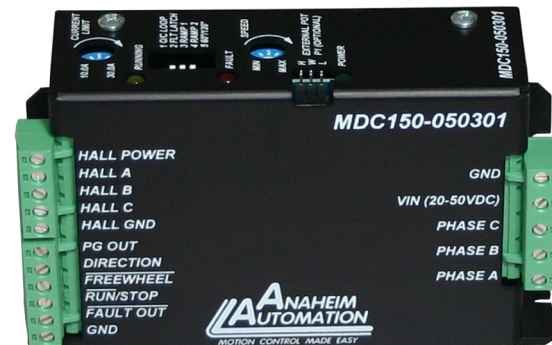

## FEATURES

- **Maximum Current Limit Setting from 10.0-30.0Amps (Peak)**
- **Hall Sensor Feedback**
- **Constant Velocity Mode**
- **Short Circuit Protection**
- **Brake, Disable and Direction Inputs**
- **Selectable Ramp Up/Down**
- **Require 20-50 VDC**
- **TTL-CMOS Compatible Inputs**
- **Compact Size (5.25 x 3.06 x 1.65)**
- **Dual Mounting Option**
- **CE Certified and RoHS Compliant**



## DESCRIPTION

The MDC150-050301 driver is designed to drive DC brushless motors at currents of up to 30A (peak) and 50V. The current limit can be set with an adjustable potentiometer right on the top of the driver. It also features hall sensor feedback and a constant velocity mode so you can overcome occasional torque spikes without slowing down.

The MDC150-050301 is also easy to use. It has screw down style detachable terminal blocks which make it easy to wire. It features LED's that indicate power and faults which make problems easy to diagnose. It also features a "running" LED so you can see if the motor is running without actually seeing the shaft. This can be useful in identifying mechanical problems in a machine without removing the motor.

The driver is protected against over current (cycle-by-cycle or latched), hall sensor error and under voltage. When an error occurs, a fault light notifies the user. If the fault latch is enabled and an error occurs, the fault output goes low to notify the user. Included on the driver is an internal potentiometer to control the maximum phase current allowed into the motor and an internal potentiometer to control the speed of the motor. An optional external potentiometer (10K) or external voltage (1-4VDC) can be used to control the speed as well.

The direction of the motor can be preset by the direction control input. Other inputs to the drive include a run/stop and a motor freewheel input. When using the run/stop input, there are three ramp up/down profiles from standstill to select from. The run/stop input overrides all other inputs into the driver.

### Ideal Applications

Automated machinery or processes that involve food, cosmetic, or medical packaging, labeling, or tamper-evident requirements, cut-to-length applications, electronic assembly, robotics, factory automation, special filming and projection effects, medical diagnostics, inspection and security devices, conveyor and material handling systems, metal fabrication (CNC machinery), pump flow control, XY and rotary tables, equipment upgrades or wherever precise positioning or speed control is required.

## DIMENSIONS

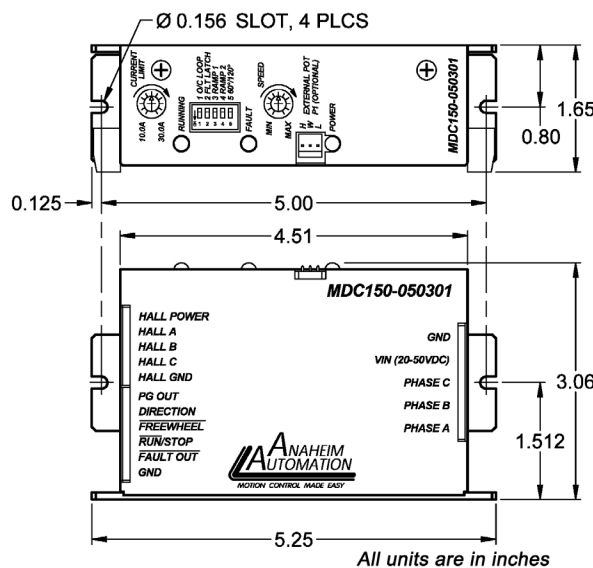

L010380

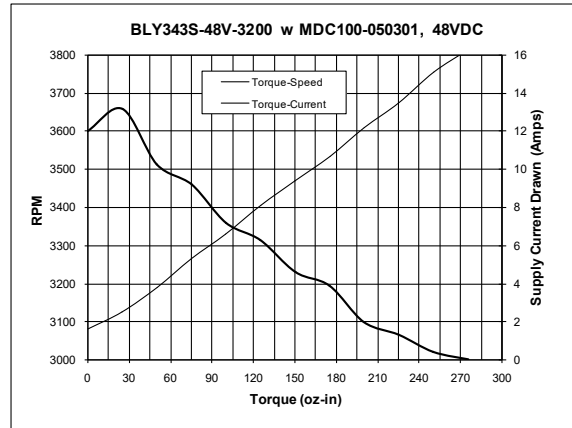
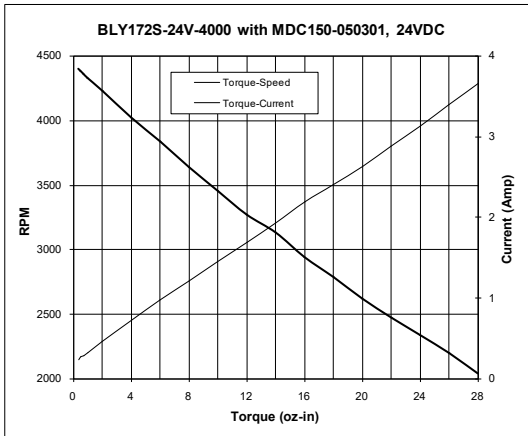

Power Requirements:	20 - 50 VDC
Output Current Range:	10.0 - 30.0 Amps (Peak) 1.0 - 5.0 Amps (Continuous)
Hall Sensor Power Output:	6.25V @ 30mA (Max.)
Control Inputs:	(TB3, Pin2-4) TTL-CMOS Compatible Logic "0" = 0 - 0.8VDC Logic "1" = Open
Freewheel:	(TB3, Pin 3) Logic "1" (open) - Motor is Enabled Logic "0" = Motor is de-energized and will coast
Fault Output:	(TB3, Pin 5) Logic "1" (5V out) - normal operation <i>Enabled when fault latch is enabled.</i> Logic "0" - 1 of 3 fault conditions in 'Fault Protection' section
Run/Stop:	Logic "1" (open) - Motor will not run and will decelerate if running Logic "0" - Motor will run and accelerate according to ramp dip switch setting
Operating Temperature:	0°C to +70° C
Driver Type:	Bipolar, Compatible with 4, 6, and 8 Lead Motors. Series or Parallel connection.
Maximum Closed Loop Motor Speed	2 pole: 30,000 RPM 4 pole: 15,000 RPM 6 pole: 11,250 RPM 8 pole: 7,500 RPM
Maximum Open Loop Motor Speed	50,000 RPM

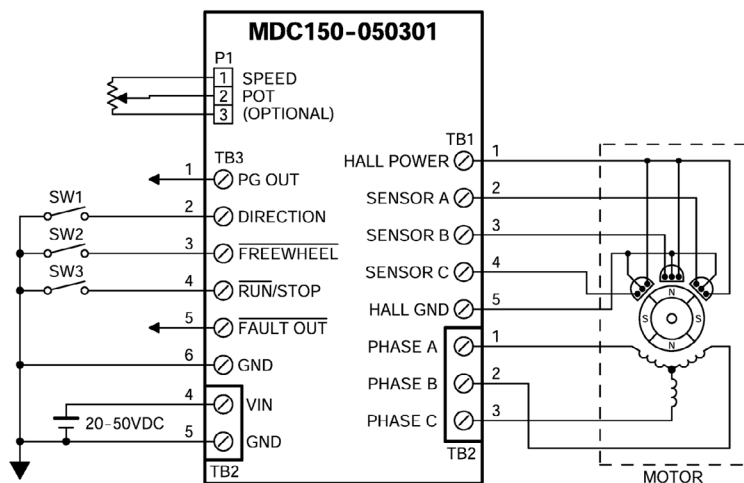

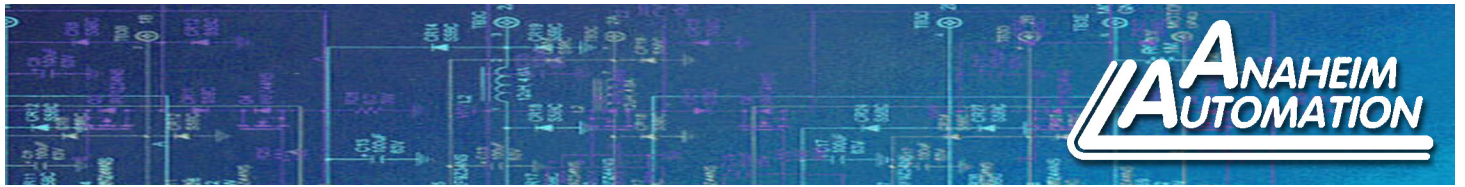

ADDITIONAL INFORMATION

Model #	Description
PSA24V2.7A	DC Power Supply 24VDC at 2.7 Amps
PSA40V4A	DC Power Supply 40VDC at 4.0 Amps
PSA40V8A	DC Power Supply 40VDC at 8 Amps